



Structure Mounted parkVUE LED Area Light Fixtures

MODEL | PS2

Catalog number:
Type:
Notes:

FEATURES & SPECIFICATIONS

Intended Use

The parkVUE is Relume's low bay LED fixture is the energy saving solution for parking structures, canopies, tunnels and downlight applications.

Construction

Housing is made from extruded aircraft quality 6061 aluminum and powder coated with high-performance polyester resin for a rugged and maintenance-free life. Patented Relume Silver Circuitry™ ensures excellent thermal management and low LED junction temperatures—the key to long LED life. The LED light engine is protected by a high-impact, UV stabilized, non-yellowing lens. A light diffusing prismatic lens is also available.

Electrical

Each power supply (driver) operates over voltages ranging from 120-277 or 377-480 volts (50/60 Hz). The driver is highly efficient with a power factor of greater than 0.98 and a total harmonic distortion (THD) of less than 20%. Fluctuations in line voltage have no effect on luminous output. Drivers have voltage surge protection to withstand high repetition noise transients. Unit meets radio frequency interference (RFI) emission limits set forth in FCC Title 47, Subpart B, Section 15.

Quality Assurance

Relume designs and builds its products to meet or exceed industry-quality standards and references including American National Standards Institute (ANSI), American Society for Testing and Materials International (ASTM), Council of the European Union (EC), Federal Trade Commission (FTC), Illuminating Engineering Society of North America (IESNA or IES), Institute of Electrical and Electronics Engineers (IEEE), National Electrical Manufacturers Association (NEMA), National Fire Protection Association (NFPA), Underwriters Laboratories (UL), Edison Testing Labs (ETL), Design Lights Consortium (DLC) and International Dark Sky (IDA). In production, each light fixture is certified by Relume's internal QA process. A quality control tracking label, including date of manufacture, is mounted on the inside of each fixture for full ISO 9001:2008 compliance. Relume guarantees unsurpassed quality by offering an industry leading 7 year limited warranty.

Eco-Friendly

All Relume Light Engines and fixtures fully comply with the Restriction of Hazardous Substances Directives (RoHS) adopted in February 2003 by the European Union and are fully recyclable.

Ordering example: PV PS2 D3 CL CW UL1 1 1 AB

FAMILY	TYPE	DISTRIBUTION
PV = ParkVue	PS2	D3 = Type 3 D5 = Type 5

LENS	COLOR TEMP	VOLTAGE	CONTROLS	MOUNTING	EXTERIOR COLOR
CL = Clear PR = Prismatic	CW = Cool White (5500K) NW = Neutral White (4500 K) WW = Warm White (3500 K)	Single Circuit UL1 = 120/277 UH1 = 347/480* Dual Circuit UL2 = 120/277 UH2 = 347/480*	1 = Sentinel 2 = Occupancy Sensor X = None	1 = Ceiling 2 = Trunion 3 = Arm 4 = Pendant	AB = Architectural Bronze EG = Electric Grey WH = White
* Not control enabled					

parkVUE LED Area Light Fixtures: Standard Dimensions:

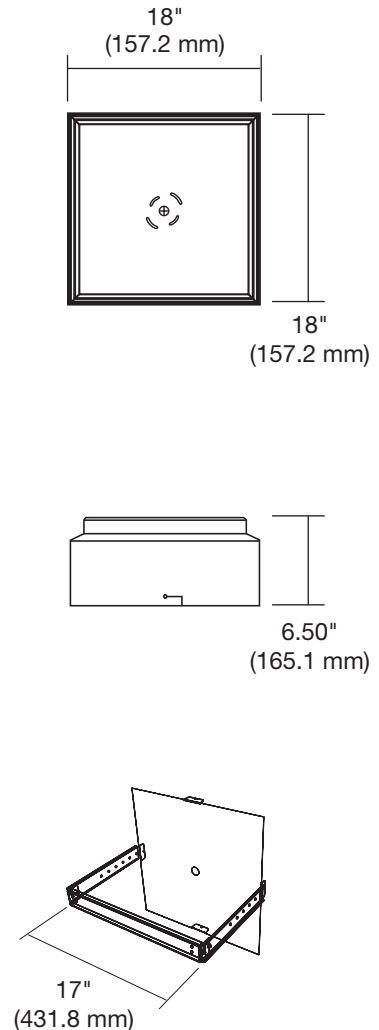

Weight:
Between 26.9 lbs. and 40.9 lbs.
with mounting hardware



Warranty

Relume guarantees unsurpassed quality by offering an industry leading 7 year limited warranty. Contact Relume for complete warranty language, exceptions, and limitations.

Relume parkVUE LED Area Light Fixtures | FEATURES & SPECIFICATIONS





Structure Mounted
parkVUE LED Area Light Fixtures

FEATURES & SPECIFICATIONS

PS2

LTL Report #15125

Initial Delivered Lumens: 6761
System Watts: 118W

EPA (Effective Projected Area):
.82 sq. ft.

Relume parkVUE LED Area Light Fixtures

FEATURES & SPECIFICATIONS

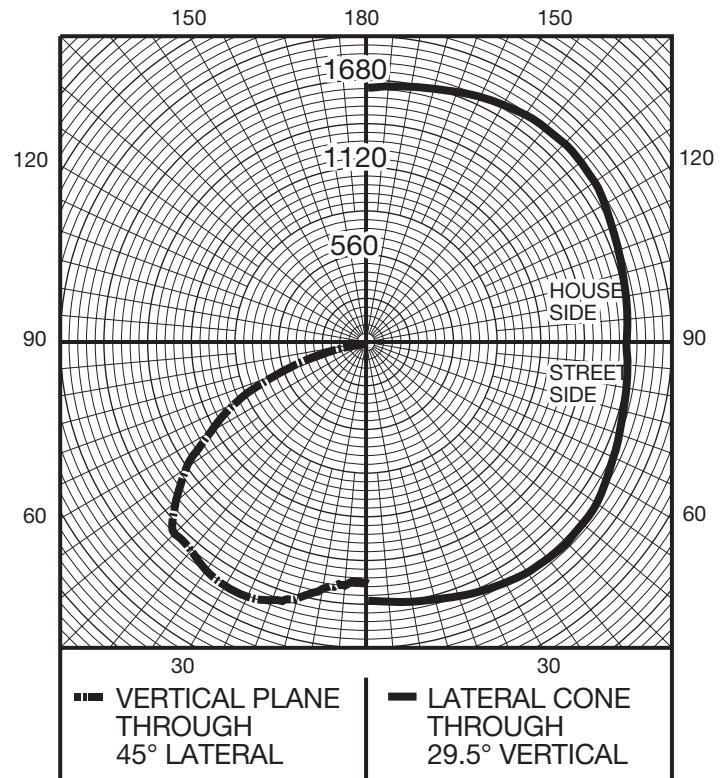
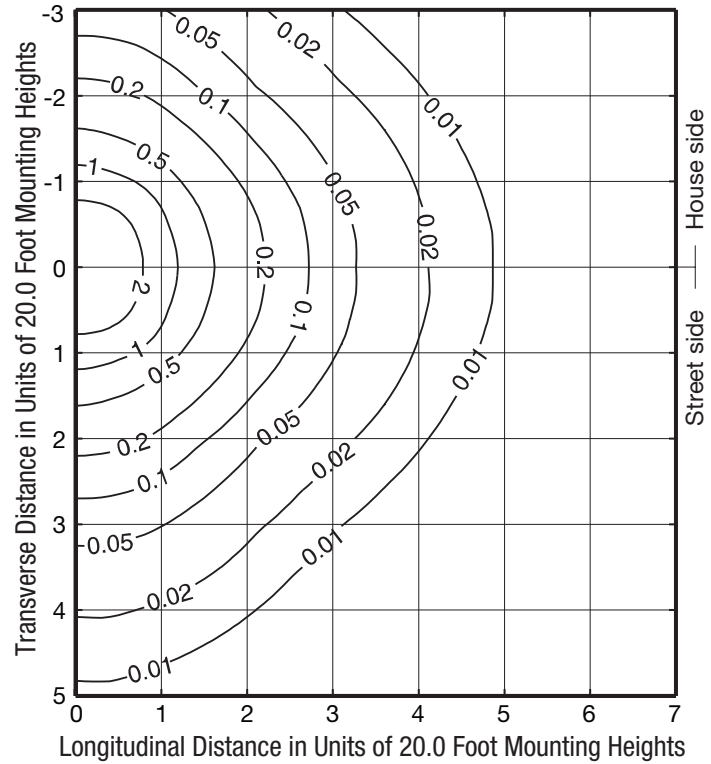

All photometric testing was conducted by Luminaire Testing Laboratory, Inc.

Testing was performed in accordance with IES LM-79-08.

