



# Outdoor Lighting Systems

## VUE Roadway LED Light Fixtures

MODEL | 400

Catalog number:
Type:
Notes:

### FEATURES & SPECIFICATIONS

#### Intended Use

The VUE™ family of street and roadway fixtures are designed to meet the requirement of local streets, roadways and highways.

#### Construction

Housing is made from extruded aircraft quality 6061 aluminum and powder coated with high-performance polyester resin for a rugged and maintenance-free life. Proprietary Copper Composite™ heat management systems ensures excellent thermal management and low LED junction temperatures—the key to long LED life. The LED light engine is protected by a high-impact, UV stabilized, non-yellowing lens. Topside toolless access to the slip-fitter and terminal block for easy wiring and installation.

#### Electrical

Each power supply (driver) operates over voltages ranging from 120-277 or 377-480 volts (50/60 Hz). The driver is highly efficient with a power factor of greater than 0.98 and a total harmonic distortion (THD) of less than 20%. Fluctuations in line voltage have no effect on luminous output. Drivers have voltage surge protection to withstand high repetition noise transients. Unit meets radio frequency interference (RFI) emission limits set forth in FCC Title 47, Subpart B, Section 15.

#### Quality Assurance

Relume designs and builds its products to meet or exceed industry-quality standards and references including American National Standards Institute (ANSI), American Society for Testing and Materials International (ASTM), Council of the European Union (EC), Federal Trade Commission (FTC), Illuminating Engineering Society of North America (IESNA or IES), Institute of Electrical and Electronics Engineers (IEEE), National Electrical Manufacturers Association (NEMA), National Fire Protection Association (NFPA), Underwriters Laboratories (UL), Edison Testing Labs (ETL), Design Lights Consortium (DLC) and International Dark Sky (IDA). In production, each light fixture is certified by Relume's internal QA process. A quality control tracking label, including date of manufacture, is mounted on the inside of each fixture for full ISO 9001:2008 compliance. Relume guarantees unsurpassed quality by offering an industry leading 7 year limited warranty.

#### Eco-Friendly

All Relume Light Engines and fixtures fully comply with the Restriction of Hazardous Substances Directives (RoHS) adopted in February 2003 by the European Union and are fully recyclable.

Ordering example: R V320HE D2 CW UL 1 AB

FAMILY	TYPE	DISTRIBUTION	COLOR TEMP	VOLTAGE	CONTROLS	EXTERIOR COLOR
R = Roadway	V400	D2 = Type 2 D3 = Type 3	CW = Cool White (5500K) NW = Neutral White (4500 K) WW = Warm White (3500 K)	UL = 120/277 UH = 347/480*  * Not control enabled	1 = Sentinel 2 = Photo Cell 3 = Photo Cell Receptacle X = None	AB = Architectural Bronze HG = Hammered Grey

### VUE Roadway LED Light Fixtures: Standard Dimensions:

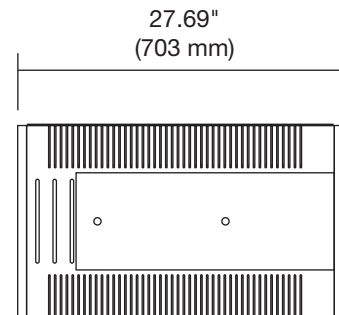
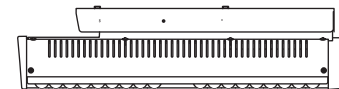
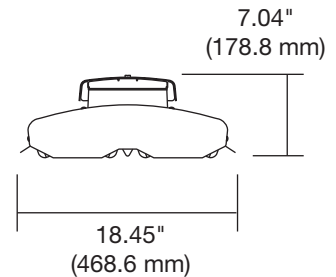

Weight: 47 lbs.

ISO 9001:2008  
CERTIFIED



#### Warranty

Relume guarantees unsurpassed quality by offering an industry leading 7 year limited warranty. Contact Relume for complete warranty language, exceptions, and limitations.

Relume VUE Roadway LED Light Fixtures | FEATURES & SPECIFICATIONS





# Outdoor Lighting Systems

## VUE Roadway LED Light Fixtures

### FEATURES & SPECIFICATIONS

## VUE400

LS Report #29410

**Initial Delivered Lumens: 14110**  
**System Watts: 260W**

EPA (Effective Projected Area):  
 1.35 sq. ft.

*All photometric testing was conducted by Lighting Sciences Inc.*

*Testing was performed in accordance with IES LM-79-08.*

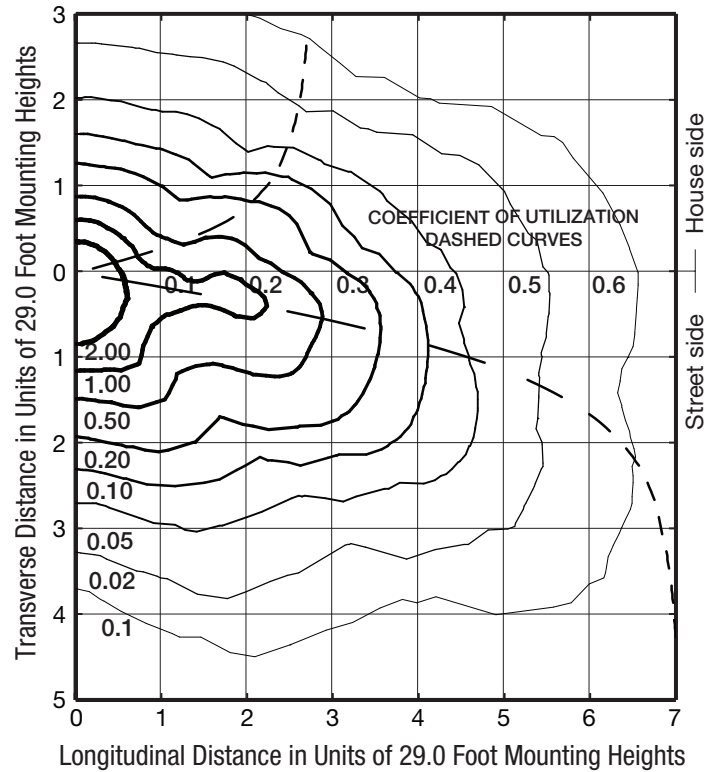

INTENSITY (CANDLEPOWER) IN MAX. PLANE		INTENSITY (CANDLEPOWER) IN MAX. CONE	
ANGLE	CANDLEPOWER	ANGLE	CANDLEPOWER
0.0	3513	0.0	1152
5.0	3592	5.0	1194
10.0	3541	15.0	1674
15.0	3389	25.0	2459
20.0	3163	35.0	3010
25.0	2862	45.0	2858
30.0	2586	55.0	5603
35.0	2442	60.0	7371
40.0	2611	62.5	8291
45.0	3149	65.0	9338
50.0	4022	67.5	10304
52.5	4370	70.0	10914
55.0	5001	72.5	11385
57.5	5983	75.0	11859
60.0	7685	77.5	12671
62.5	9879	80.0	13254
65.0	12162	82.5	12795
67.5	13254	85.0	11535
70.0	12704	87.5	9672
72.5	10964	90.0	7660
75.0	7713	95.0	4948
77.5	4364	105.0	3644
80.0	2389	115.0	1970
82.5	1237	125.0	783
85.0	366	135.0	699
87.5	145	145.0	600
90.0	67	155.0	476
95.0	4	165.0	445
105.0	1	175.0	435
115.0	0	180.0	421
125.0	0		
135.0	0		
145.0	0		
155.0	0		
165.0	0		
175.0	0		
180.0	0		

### WITH CLEAR CURVED PLASTIC LENSES OVER LEDS

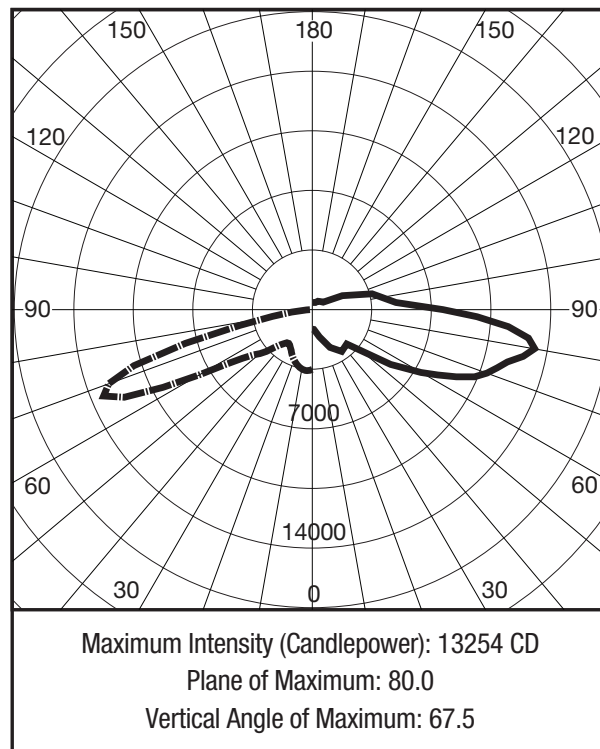

Relume VUE Roadway LED Light Fixtures | FEATURES & SPECIFICATIONS