



# Retrofit Streetlight System UA/Teardrop

Catalog number:
Type:
Notes:

MODEL | Teardrop

## FEATURES & SPECIFICATIONS

### Intended Use

Ideal for lighting main streets, municipalities and parking lots.

### Construction

Relume UA light engines are made of high grade aluminum. All models are wet rated. All units are tested for vibration and shock resistance. Patented Relume Silver Circuitry™ ensures excellent thermal management and low LED junction temperatures – the key to long LED life.

### Electrical

Each power supply (driver) operates over voltages ranging from 120-277 or 377-480 volts (50/60 Hz). The driver is highly efficient with a power factor of greater than 0.98 and a total harmonic distortion (THD) of less than 20%. Fluctuations in line voltage have no effect on luminous output. Drivers have voltage surge protection to withstand high repetition noise transients. Unit meets radio frequency interference (RFI) emission limits set forth in FCC Title 47, Subpart B, Section 15.

### Quality Assurance

Relume designs and builds its products to meet or exceed industry-quality standards and references including American National Standards Institute (ANSI), American Society for Testing and Materials International (ASTM), Council of the European Union (EC), Federal Trade Commission (FTC), Illuminating Engineering Society of North America (IESNA or IES), Institute of Electrical and Electronics Engineers (IEEE), National Electrical Manufacturers Association (NEMA), National Fire Protection Association (NFPA), Underwriters Laboratories (UL), Edison Testing Labs (ETL), Design Lights Consortium (DLC) and International Dark Sky (IDA). In production, each light fixture is certified by Relume's internal QA process. A quality control tracking label, including date of manufacture, is mounted on the inside of each fixture for full ISO 9001:2008 compliance. Relume guarantees unsurpassed quality by offering an industry leading 7 year limited warranty.

### Installation

Installation usually takes 15 minutes or less and is easily accomplished by one worker. Connection to a photocell, if required, is straight forward. Relume light engines are designed to work with most commonly used fitters.

### Retrofit Streetlight UA Acorn LED: Standard Dimensions:

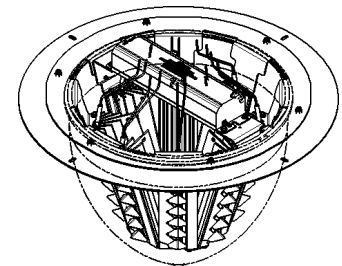
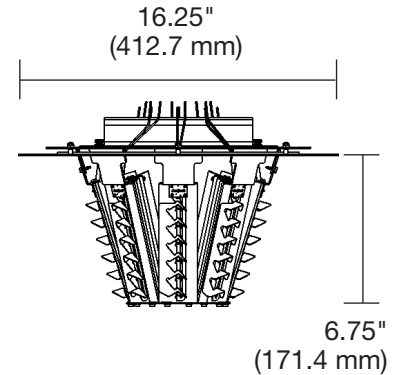

Ordering example: UA T D3 CW UL 1

FAMILY	TYPE	DISTRIBUTION	COLOR TEMP	VOLTAGE	CONTROLS
UA = Universal Area	T = Teardrop	D3 = Type 3 D5 = Type 5 D3C = Type 3, Cutoff D5C = Type 5, Cutoff	CW = Cool White (5500K) NW = Neutral White (4500 K) WW = Warm White (3500 K)	UL = 120/277 UH = 347/480	1 = Sentinel 2 = Sentinel Ready X = None



### Warranty

Relume guarantees unsurpassed quality by offering an industry leading 7 year limited warranty. Contact Relume for complete warranty language, exceptions, and limitations.

Relume Retrofit Streetlight System UA FEATURES & SPECIFICATIONS





# Retrofit Streetlight System UA/Teardrop

## FEATURES & SPECIFICATIONS

### Teardrop

LTL Report #19089

**Initial Delivered Lumens: 4702**  
**System Watts: 74W**

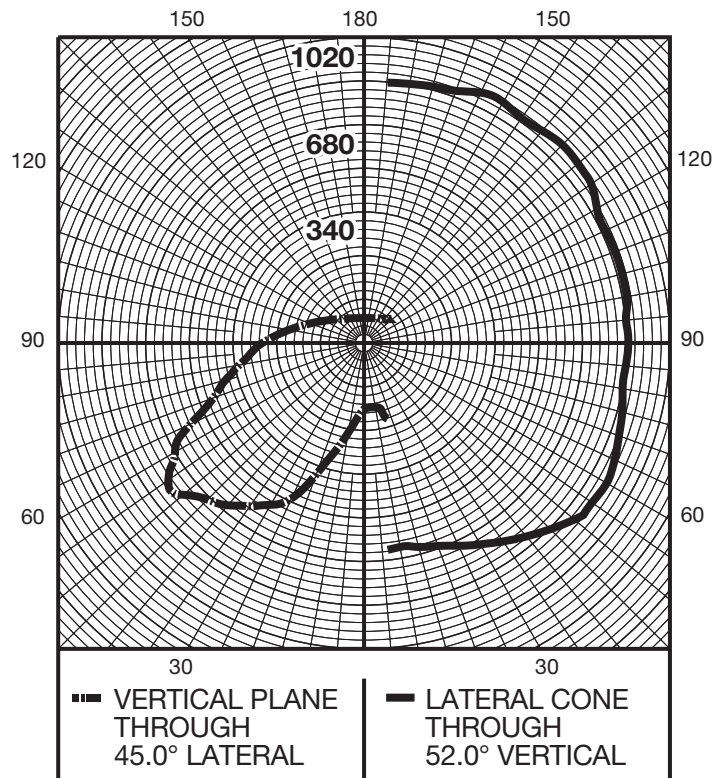
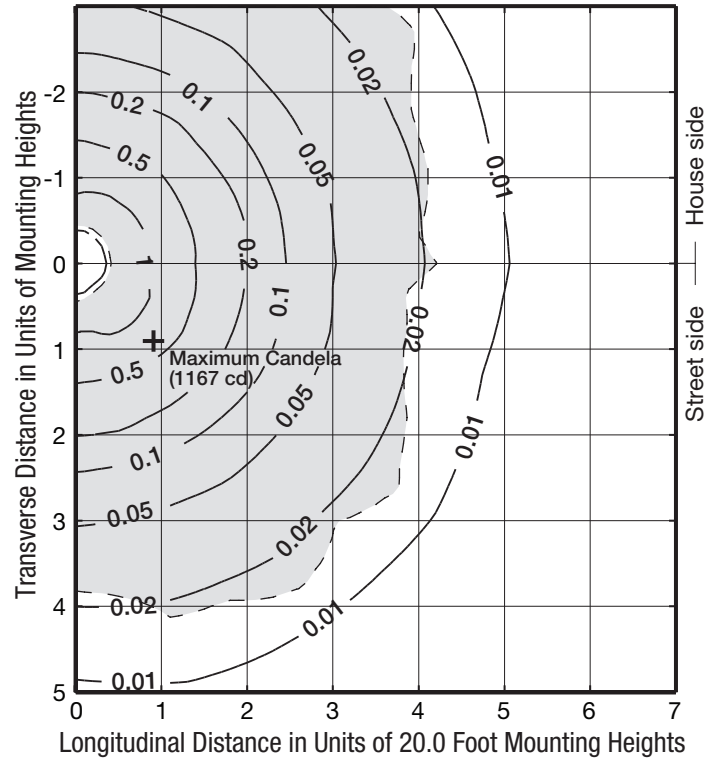

All photometric testing was conducted by Luminaire Testing Laboratory, Inc.

Testing was performed in accordance with IES LM-79-08.

